

VOLVO ARTICULATED HAULER

A25C

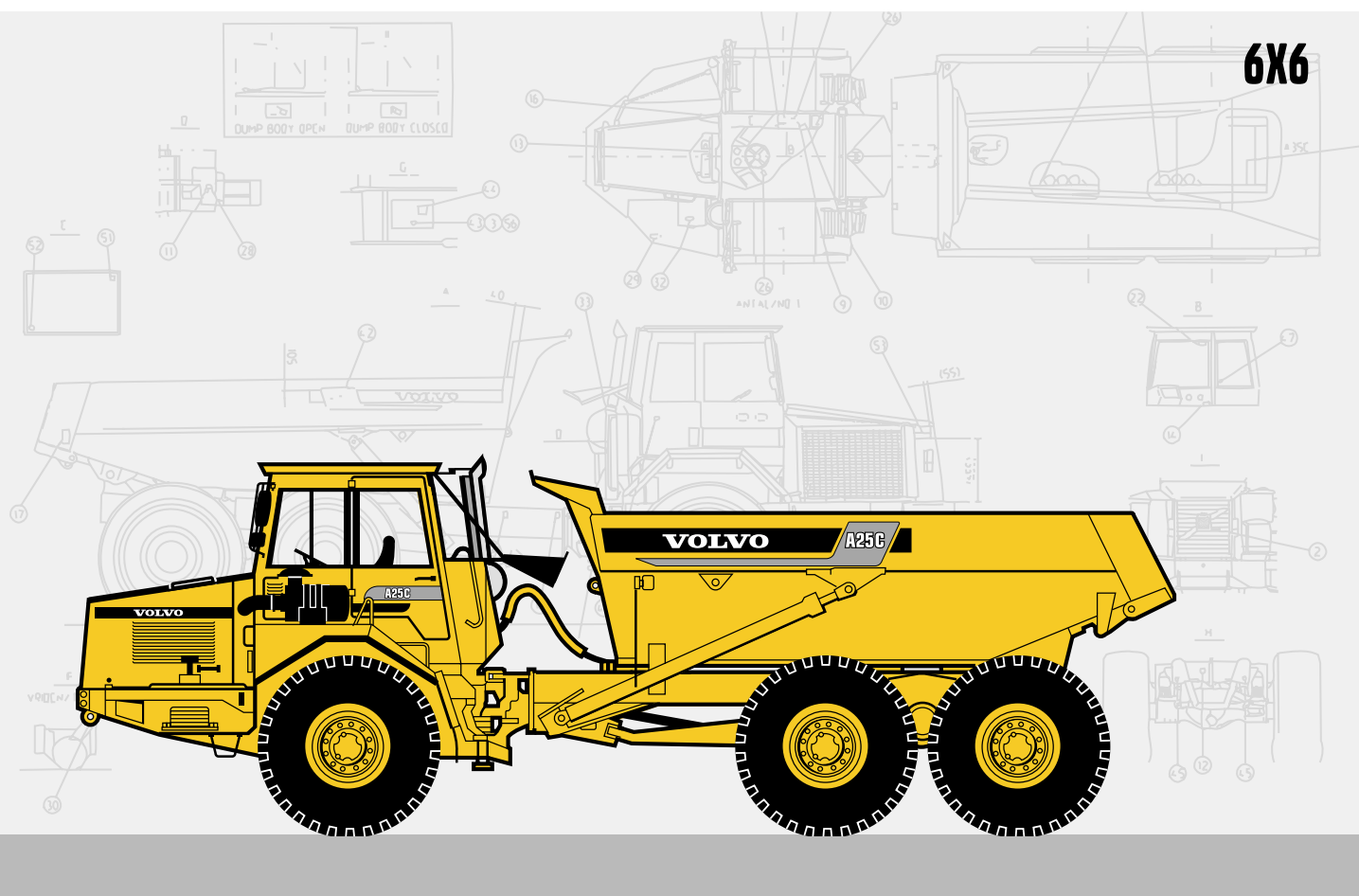

- Engine output SAE J1349:
Net 187 kW (251 hp)
Gross 190 kW (255 hp)
- Body volume:
13,5 m³ (17.7 yd³)
- Load capacity:
22,5 t (25 sh tn)
- Volvo low emission direct-injected, turbocharged, inter-cooled high performance diesel engine.
- Fully automatic powershift transmission, electronically controlled.
- Drop box with longitudinal differential lock and high and low gear ranges.
- Hydraulic retarder as standard.
- 100% lock-up differential locks. One longitudinal and three transverse diff-locks.
- Front axle with three-point suspension and effective shock absorption.
- Volvo terrain bogie, individually oscillating axles and high ground clearance.
- Load and dump brake.
- Low interior noise level.
- Adjustable steering wheel.

VOLVO



ENGINE

Volvo 6-cylinder, in-line, turbocharged, direct-injected, inter-cooled, 4-cycle low emission diesel engine with overhead valves and wet replaceable cylinder linings. Meets 88/77/EEC and California off-road regulation 1996.

Fan: Hydrostatic driven, thermostatically controlled radiator fan consuming power only when needed.

| | |
|------------------------------|-------------------------------|
| Make | Volvo |
| Model | TD73 KCE |
| Max power at | 40 r/s (2400 r/min) |
| SAE J1349 Gross | 190 kW (255 hp) |
| Flywheel power at | 40 r/s (2400 r/min) |
| SAE J1349 Net | 187 kW (251 hp) |
| DIN 6271* | 187 kW (251 hp) |
| Max torque at | 20 r/s (1200 r/min) |
| SAE J1349 Gross | 1090 Nm (804 lbf ft) |
| SAE J1349 Net | 1080 Nm (796 lbf ft) |
| DIN 6271** | 1080 Nm (796 lbf ft) |
| Displacement total | 6,73 l (411 in ³) |
| Bore | 105 mm (4.1 in) |
| Stroke | 130 mm (5.1 in) |
| Compression ratio | 17,7:1 |

*) with fan at normal speed. With fan operating at full speed the flywheel power is 174 kW (233 hp) which corresponds to DIN 70020.

**) with fan at normal speed. With fan operating at full speed the maximum torque is 970 Nm, which corresponds to DIN 70020.



ELECTRICAL SYSTEM

| | |
|----------------------------|----------------|
| Voltage | 24 V |
| Battery capacity | 2x135 Ah |
| Alternator | 1,65 kW (60 A) |
| Starter motor | 5 kW (6.7 hp) |



SERVICE CAPACITIES

| | |
|------------------------------|---------------------|
| Crankcase | 24 l (6.3 US gal) |
| Fuel tank | 280 l (74.0 US gal) |
| Cooling system | 37 l (9.8 US gal) |
| Transmission total | 16 l (4.2 US gal) |
| Drop box | 6 l (1.6 US gal) |
| Front axle | 27 l (7.1 US gal) |
| First bogie axle | 28 l (7.4 US gal) |
| Second bogie axle | 27 l (7.1 US gal) |
| Brake hydraulics | 2 l (0.5 US gal) |
| Hydraulic system | 180 l (47.6 US gal) |
| Hydraulic tank | 155 l (41 US gal) |



DRIVETRAIN

Torque converter: Single stage with free wheeling stator and automatic lock-up in all gears.

Transmission: Electronically controlled, fully automatic planetary transmission with 5 gears forward and 1 in reverse.

Drop box: Volvo with 2-stage design, power take-off and differential with lock-up function.

Axles: Volvo. 6-wheel drive. All axles have transversal diff-locks with 100% lock-up and fully floating axle shafts with planetary type hub reductions.

Differential locks: One longitudinal and three transverse. All with 100% lock-up.

| | |
|----------------------------|-------------------------|
| Torque converter | 2,4:1 |
| Transmission | Volvo PT 1051 (5HP 500) |
| Drop box | Volvo FL 652 |
| Axles | Volvo AH 54 |

Speeds with tires 23.5R25

| | |
|-------------------|-----------------------|
| Low gear, forward | |
| 1 | 6 km/h (3.7 mile/h) |
| 2 | 10 km/h (5.6 mile/h) |
| 3 | 17 km/h (10.6 mile/h) |
| 4 | 24 km/h (14.9 mile/h) |
| 5 * | 34 km/h (21.1 mile/h) |

| | |
|--------------------|-----------------------|
| High gear, forward | |
| 1 | 9 km/h (5.6 mile/h) |
| 2 | 15 km/h (9.3 mile/h) |
| 3 | 26 km/h (16.2 mile/h) |
| 4 | 37 km/h (23.0 mile/h) |
| 5 ** | 52 km/h (32.3 mile/h) |

| | |
|-------------------|---------------------|
| Low gear, reverse | |
| 1 *** | 7 km/h (4.3 mile/h) |

| | |
|--------------------|----------------------|
| High gear, reverse | |
| 1 **** | 11 km/h (6.8 mile/h) |

with tires 20.5R25:

| | |
|------|-----------------------|
| * | 32 km/h (19.9 mile/h) |
| ** | 48 km/h (29.8 mile/h) |
| *** | 6 km/h (3.7 mile/h) |
| **** | 10 km/h (6.2 mile/h) |



SUSPENSION

Volvo suspension system. Totally maintenance-free.

Front axle: Two rubber springs with bottoming absorption on each side. Stabilizer. Two shock absorbers on each side. The front axle is suspended at three points, which results in oscillating needed in rough terrain.

Bogie: Volvo's unique terrain bogie, which permits individual oscillation between the axles.



BRAKE SYSTEM

Dual circuit system with air-hydraulic disc brakes. Comply with ISO 3450 and SAE J1473 at total machine weight.

Circuit Division: One circuit for front axle and one for bogie axles.

Parking brake: Spring-applied, air-released disc brake on the propeller shaft, designed to hold a loaded machine on a grade up to 18%. When the parking brake is applied, the longitudinal differential is locked.

Load and dump brake: With the engine running, the service brake on the bogie axles is applied together with the parking brake.

Compressor: Gear-driven by engine transmission.

Exhaust brake: Standard.

Retarder: Hydraulic, integrated in transmission as standard. Infinitely variable with the retarder pedal or full effect applied via the service brake pedal.

For retarding capability incl. retarder, exhaust brake and engine, see graph on page 4.



HYDRAULIC SYSTEM

Pumps: Three engine-dependent, variable piston pumps mounted on flywheel power take-offs. One unused power take-off available.

Ground-dependent hydraulic pump for supplementary steering mounted on the drop box.

Filtration: Through two paper filters with magnetic cores.

| | |
|---|-------------------------|
| Pump capacity per pump at shaft speed | 34 r/s (2040 r/min) |
| engine dependent | 100 l/min (26.4 US gpm) |
| ground dependent | 118 l/min (31.2 US gpm) |
| Working pressure | 19,5 MPa (2830 psi) |



CAB

Volvo cab, tested and approved according to ROPS standard ISO/3471 and SAE J1040/APR88.

Mounted on rubber pads which effectively reduce vibrations. Adjustable steering wheel.

Radio/ Contronic console in ceiling.

Heater and defroster: Filtered air and pressurized cab. Three speed fan.

Operator's seat: Ergonomically designed and adjustable operator's seat with flameproof upholstery. Retractable seat belt.

Trainer seat: Option.

| | |
|--|-----------|
| Number of exits | 2 |
| Internal sound level, according to ISO 6394 and at max speed | 78 dB (A) |



STEERING SYSTEM

Hydromechanical articulated steering with mechanical feedback. 3,4 lock-to-lock turns.

Cylinders: Two double-acting steering cylinders.

Supplementary steering: Complies with ISO 5010 standard at total machine weight.

Steering angle: ± 45°



BODY

Body: Hardened and tempered steel body with high impact strength.

Cylinders: Two single stage double-acting hoist cylinders.

| | |
|----------------------------------|-------------------------------------|
| Tipping angle | 70° |
| Tipping time with load | 15 s |
| Lowering time | 12 s |
| Body, plate thickness | |
| Front | 8 mm (0.31 in) |
| Sides | 12 mm (0.47 in) |
| Bottom/chute | 14 mm (0.55 in) |
| Yield strength | 1000 N/mm ² (145000 psi) |
| Tensile strength | 1250 N/mm ² (181000 psi) |
| Hardness min. | 360–440 HB |



WEIGHTS

Operating weight includes all fluids and operator. Standard machine.

Operating weight with 23.5R25 tires:

| | |
|-------------------|----------|
| Front | 9040 kg |
| Rear | 8730 kg |
| Total | 17770 kg |
| Payload | 22500 kg |
| Total weight | |
| Front | 11500 kg |
| Rear | 28770 kg |
| Total | 40270 kg |

A25C with 20.5R25 tyres, subtract 200 kg (440 lb) per axle.



GROUND PRESSURE

At 15% sinkage of unloaded radius and specified weights.

| With tires | 20.5R25 | 23.5R25 |
|------------|--------------------|--------------------|
| Unloaded | | |
| Front | 110 kPa (15.9 psi) | 91 kPa (13.2 psi) |
| Rear | 52 kPa (7.5 psi) | 44 kPa (6.4 psi) |
| Loaded | | |
| Front | 141 kPa (20.4 psi) | 116 kPa (16.8 psi) |
| Rear | 177 kPa (25.7 psi) | 145 kPa (21.0 psi) |

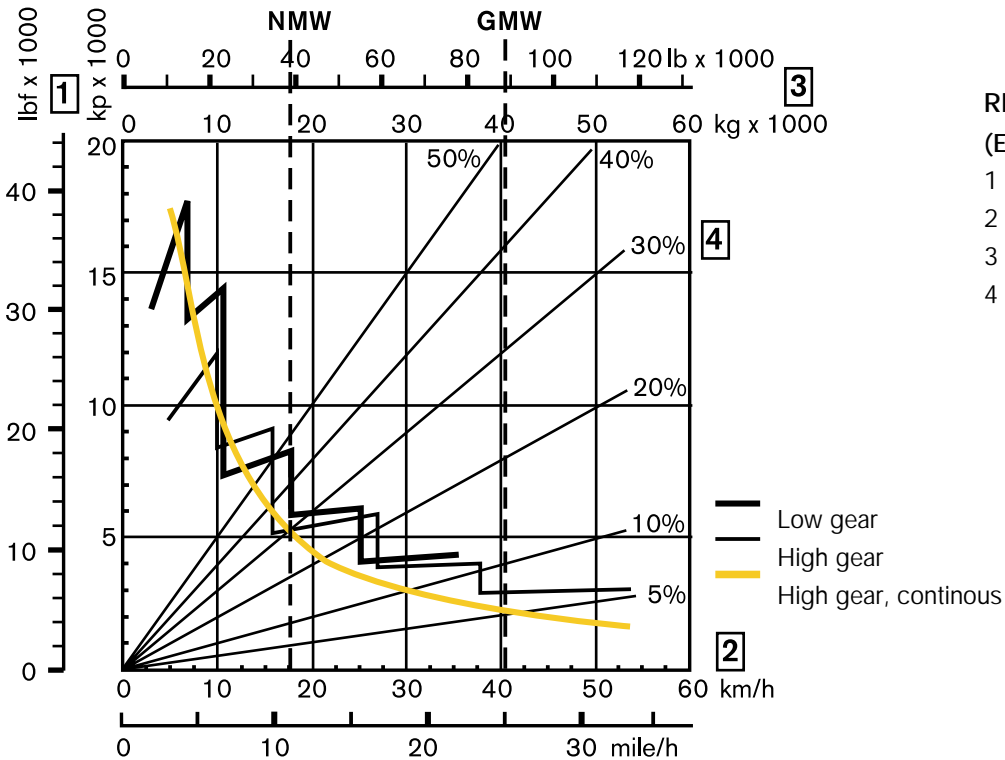
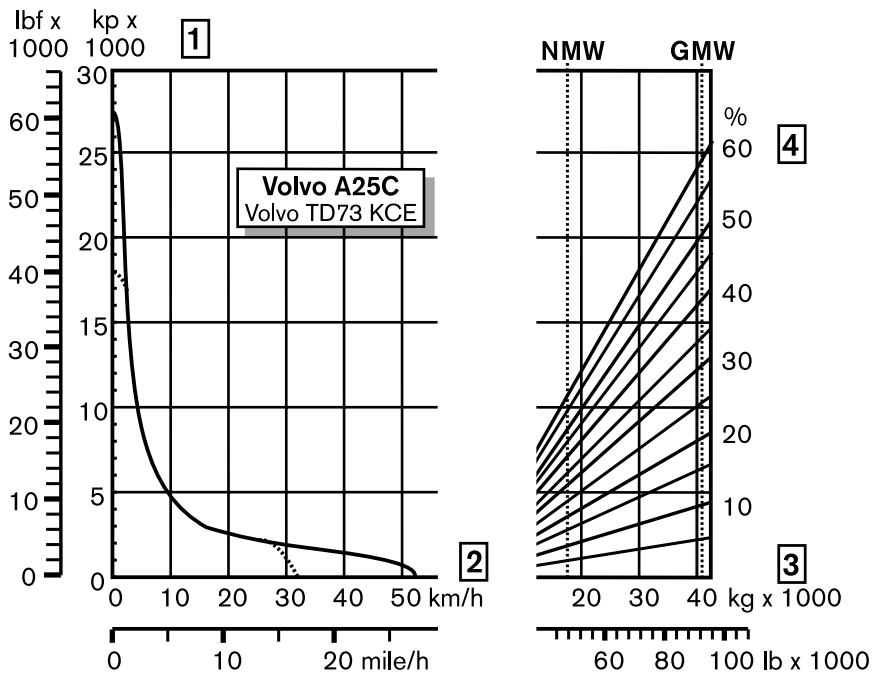

INSTRUCTIONS

Diagonal lines represent total resistance (grade % plus rolling resistance %).

Charts based on 0% rolling resistance, standard tyres and gearing, unless otherwise stated.

In the retardation chart the diagonal lines represent the "total resistance" as well (here in downhill grades it is the total extra pushing force), which is the grade in % minus the rolling resistance in %.

- Find the diagonal line with the appropriate total resistance on the right-hand edge of the chart.
- Follow the diagonal line downward until it intersects the actual machine weight line, NMW or GMW.
- Draw a new line horizontally to the left from the point of intersection until the new line intersects the rimpull or retardation curve.
- Read down for vehicle speed.

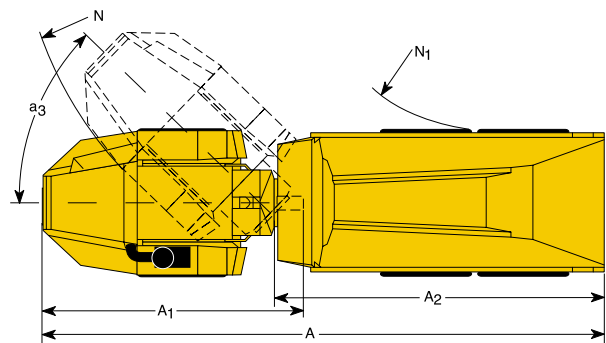
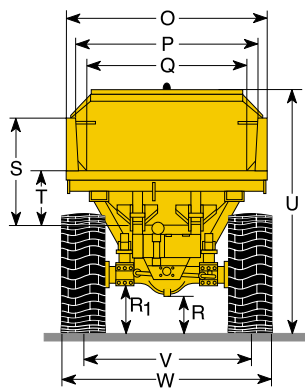
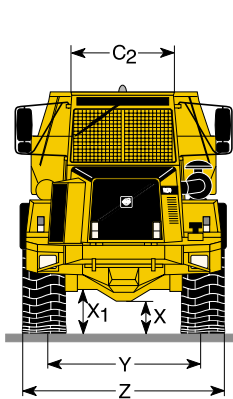
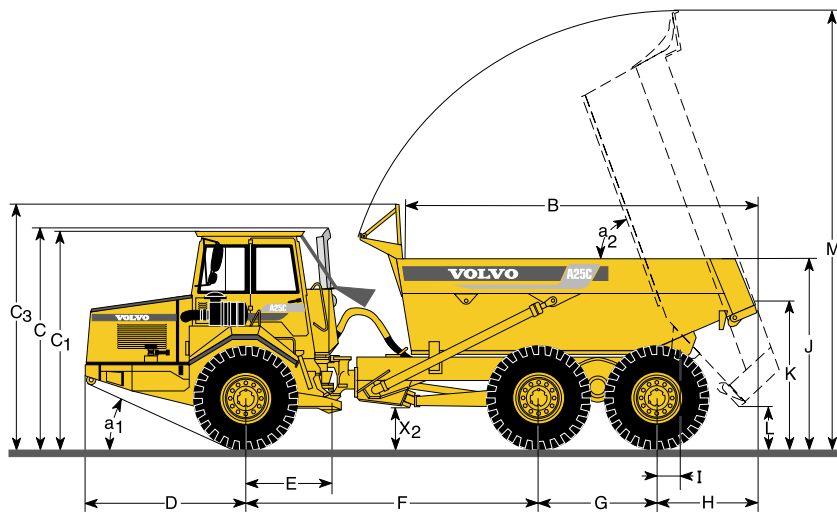

DIMENSIONS Volvo A25C 6x6 (unloaded with 23.5R25 tires)

| | | | | | | | |
|----------------|--|---|-----------------|----------------|------------------|----------------|----------------|
| A | 9675 mm (31'9") | E | 1200 mm (3'11") | N | 7850 mm (25'9") | V | 2150 mm (7'6") |
| A ₁ | 4495 mm (14'9") | F | 4165 mm (13'8") | N ₁ | 4250 mm (13'11") | W | 2795 mm (9'2") |
| A ₂ | 5710 mm (18'9") | G | 1670 mm (5'6") | O | 2500 mm (8'2") | X | 480 mm (1'7") |
| B | 5000 mm (16'5") | H | 1425 mm (4'8") | P | 2300 mm (7'7") | X ₁ | 610 mm (2') |
| C | 3285 mm (10'9") | I | 385 mm (1'3") | Q | 2100 mm (6'11") | X ₂ | 660 mm (2'2") |
| C ₁ | 3210 mm (10'6") | J | 2780 mm (9'1") | R | 520 mm (1'8") | Y | 2150 mm (7'6") |
| C ₂ | 1320 mm (4'4") | K | 2150 mm (7'1") | R ₁ | 620 mm (2') | Z | 2795 mm (9'2") |
| C ₃ | 3571 mm (11'9") with optional spillguard in upright position | L | 640 mm (2'1") | S | 1340 mm (4'5") | a ₁ | 26° |
| D | 2415 mm (7'11") | M | 6400 mm (21') | T | 710 mm (2'4") | a ₂ | 70° |
| | | | | U | 2995 mm (9'10") | a ₃ | 45° |

DIMENSIONS Volvo A25C 6x6 (Unloaded with 20.5R25 tires)

| | | | | | | | |
|----------------|--|---|------------------|----------------|------------------|----------------|----------------|
| A | 9675 mm (31'9") | D | 2415 mm (7'11") | N | 7850 mm (25'9") | V | 1930 mm (6'4") |
| A ₁ | 4495 mm (14'9") | E | 1200 mm (3'11") | N ₁ | 4250 mm (13'11") | W | 2490 mm (8'2") |
| A ₂ | 5710 mm (18'3") | F | 4165 mm (13'8") | O | 2500 mm (8'2") | X | 420 mm (1'5") |
| B | 5000 mm (16'5") | G | 1670 mm (5'6") | P | 2300 mm (7'7") | X ₁ | 550 mm (1'10") |
| C | 3225 mm (10'7") | H | 1425 mm (4'8") | Q | 2100 mm (6'11") | X ₂ | 600 mm (2') |
| C ₁ | 3150 mm (10'4") | I | 385 mm (1'3") | R | 460 mm (1'6") | Y | 1930 mm (6'4") |
| C ₂ | 1320 mm (4'4") | J | 2720 mm (8'11") | R ₁ | 560 mm (1'10") | Z | 2490 mm (8'2") |
| C ₃ | 3271 mm (11'7") with optional spillguard in upright position | K | 2090 mm (6'10") | S | 1340 mm (4'5") | a ₁ | 24,5° |
| | | L | 580 mm (1'11") | T | 710 mm (2'4") | a ₂ | 70° |
| | | M | 6350 mm (20'10") | U | 2945 mm (9'8") | a ₃ | 45° |

LOAD CAPACITY (Body volumes according to SAE 2:1)

| | | | |
|---|---|---|---|
| Load capacity | 22 500 kg (25 sh tn) | | |
| Body, struck | 10,6 m ³ (13.9 yd ³) | | |
| heaped | 13,5 m ³ (17.7 yd ³) | | |
| With underhung tailgate (optional) | | With over- and underhung tailgate (optional) | |
| Body, struck | 11,1 m ³ (14.5 yd ³) | Body, struck | 11,2 m ³ (14.6 yd ³) |
| heaped | 13,8 m ³ (18.0 yd ³) | heaped | 14,1 m ³ (18.4 yd ³) |

STANDARD EQUIPMENT

Safety

ROPS cab
Anti-slip material on hood and fenders
Ergonomically designed and adjustable operator's seat with retractable seat belt
Hazard flashers
Horn
Protective grille for rear window
Rear-view mirrors
Seat belt
Secondary steering
Speedometer
Steering joint locking assembly
Windshield wipers with interval
Windshield washers

Comfort

Adjustable steering wheel
Ashtray
Cab heater with filtered fresh air and defroster
Cigarette lighter
Cup holder
Ergonomically designed and adjustable operator's seat
Radio/Contronic console in ceiling
Sun-visor
Tinted glass

Engine

Exhaust brake
Intercooler
Low emission engine
Oil drainage hose
Preheating
Turbocharger

Electrical system

Alternator
Battery disconnect switch
Electrical outlet
Gauges for:
• Air pressure
• Engine temperature
• Engine revolutions
• Fuel
• Hours
• Transmission oil temperature
Lights:
• Headlights, main/dipped
• Parking lights
• Direction indicators
• Rear lights
• Back-up lights
• Brake lights
• Cab lighting
• Instrument lighting
• Control panel lighting
Pilot lamps for:
• Exhaust brake
• Direction indicators
• Front axle diff-lock
• Longitudinal diff-lock
• Lights
• Main beam
• Preheating
• High/low gear

Warning lamps for:

- Air cleaner, engine
- Battery charging
- Body up
- Brake pressure
- Brake failure
- Engine oil pressure
- Engine overspeed
- Engine-dependent steering pump
- Ground-dependent steering pump
- Hydraulic oil level
- Parking brake
- Transmission temperature

Central warning:

- Air cleaner, engine
- Air pressure
- Battery charging
- Brake failure
- Engine oil pressure
- Engine overspeed
- Engine temperature
- Hydraulic oil level
- Steering function

Drivetrain

Torque converter with automatic lock-up
Automatic transmission
Hydraulic variable retarder
Drop box with high/low gear
Longitudinal diff-lock
Differential lock front axle
Differential lock first bogie axle
Differential lock second bogie axle

Brakes

Air-hydraulic disc brakes
Two circuits
Parking brake on all wheels
Retarder activation in brake pedal
Load and dump brake

Body

Body with exhaust ducts

Tires

23.5R25

OPTIONAL EQUIPMENT

Service and Maintenance

Tool kit with tyre inflation unit
Tool box
Central lubrication

Engine

Extra fuel filter
Oil-bath air cleaner
Coolant filter

Electrical

Work lights, roof mounted
Rotating beacon with collapsible mount
Side direction indicators
Headlights for left-hand traffic

Cab

Air conditioning
Airsuspended electrically heated operator's seat
Contronic display
Electrically heated rear-view mirrors
Extra seat for trainer
Radio
Kit for radio installation
Speedometer, miles
Tachograph (Europe)

Safety

Overhead guard, FOPS
Fire-extinguisher and first aid cushion

External

Brake protection, front axle
Mudguard wideners, front, 2,7 m
Rear mudflaps, 2,7 m

Body

Body heating
Overhung tailgate, wire
Overhung tailgate, link
Underhung tailgate
Wear plates, separate delivery
Upper side extensions, 200 mm
Extra front spill guard

Tyres

20.5R25

Other

Synthetic hydraulic oil (biologically degradable)
Towing hitch

Under our policy of continual product improvement, we reserve the right to change specifications and design without prior notice. The illustrations do not necessarily show the standard version of the machine.

VOLVO

Volvo Construction
Equipment Group

Ref. No 21 3 669 4089
Printed in Sweden 99.08-4
Volvo Växjö 1999

English
ART